

Pressure Safe System

Pressure Release Valve Safety System

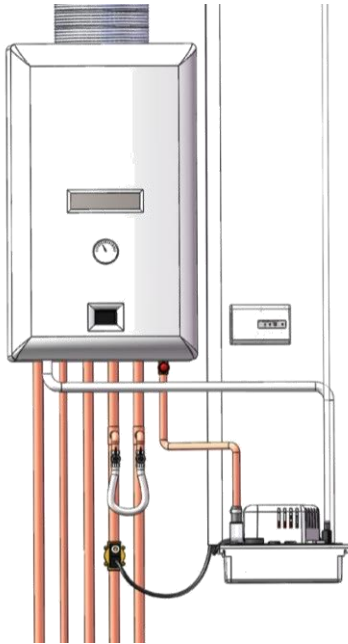

Safety first

The **pump** collects condensates. Thanks to the **diffuser** reducing the pressure, it also allows the safe discharge of the pressure relief valve inside the property.

The pump safety switch can detect if filling loop is left open, or a failure of plate-to-plate heat exchanger, or a failure of the pressure release valve.

If a failure occurs, the pump sends a signal to the **regulation box**. The regulation box closes the **solenoid valve** and stops cold water entering the boiler.

The heating stays on, hot water is stopped. A red light is activated informing the end user he must call contractor to solve the problem and reset the installation.

AVANTAGES

- **Safe installation**

- No risk of house floods.
- No risk of heating system shutting down due to frozen PRV discharge pipes.
- Notices failures and informs when contact with the contractor is needed.

- **Easy and quick installation**

- No long expensive copper pipe runs.
- No ladder work, no drilling through wall

- **Preserve the environment**

- No water loss.
- No energy loss.

KIT CONTENT



A. **Regulation box** including 2 strain reliefs and 4 screws

B. **Solenoid valve** with 2 m cable bare ends (L,N,G)

C. **Diffuser**

D. **SI1800: centrifugal pump** with tank of 2,0 l:

- Check valve
- Power cable : 2 m bare ends (L,N,G)
- Safety switch cable: 2 sleeved wires - 1,5 m bare ends

E. **PVC Tubing** : 10 mm ID, 6 m long

F. Ø10 to 10 mm (3/8" to 3/8") **straight connector** for clear tubing Ø10mm extension

G. 2 bags of 2 screws + 2 rawl plugs

H. Ø int. 15-20-24-32-40 mm (Ø int. 5/8"-3/4"-1"- 1"1/4-1"1/2) **inlet adaptor** for PVC pipe

I. Condensate **self-sealing evacuation connector**, Ø 10 mm int.

J. Ø10 to 20 mm (3/8" to 3/4") **outlet adaptor** for rigid tubing Ø20 mm

APPLICATIONS

for Gas Condensing Boilers and electric boilers:

- heating only or heating and hot water (combi)
- wall mounted or floor mounted
- in domestic use : suitable for expansion vessels ≤12l

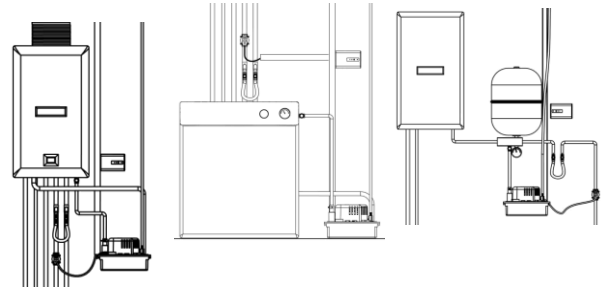

WARNING:

- **Commercial use** : carefully verify **expansion vessel size**
- If >12l, do not connect the Pressure Release Valve to the pump
- Boilers incorporating a store of hot water > 15l.

ACTUAL FLOW RATES (l/h)				
Vertical Discharge head	Total tube length (Ø int. 10 mm, 3/8")			
	5 m	10 m	20 m	30 m
1 m	380	300	240	190
2 m	310	260	200	150
3 m	240	200	145	110
4 m	150	130	80	60
5 m	30	20	0	0

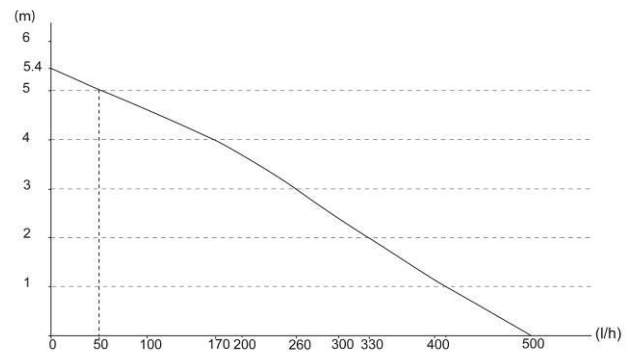

RECOMMENDED ACCESSORIES



Hose Ø int. 10mm (3/8")
 ACC00911: 25 m
 ACC00915: Braided, 25 m



Check valve
 For replacement
 Ø ext. 10 mm (3/8")
 ACC00925

TECHNICAL SPECIFICATION	
Pressure Safe System	
Safety standards	CE - EAC - UKCA
RoHS directive	Compliant
WEEE directive	Compliant
Weight (including box)	3.8 kg
Packaging	L400xW200xH215 mm
Pallet quantity	60 pieces – 5 levels of 12 pumps
Pump SI 1800 & Diffuser	
Max. flow rate	500 l/h
Max. discharge head	5 m
Max pressure	5.4 m (flowrate=0)
Sound level in application at 1m(3.3ft): ≤ 45 dBA (Measured in Sauermann acoustic lab, pump operating with water)	
Mains supply	230V~ 50Hz - 70 W – 0.67A
Detection levels	On : 53mm, Off : 42mm, Safety : 64mm
Safety switch	NC 4 A resistive – 250V
Max. condensate temperature	65°C, 80°C in short peak
Max. condensate acidity	pH > 2.5 (Gas condensing boilers)
Thermal protection (overheating)	105°C (auto-reset)
Operating conditions	30%: 3s ON – 7s OFF
Protection	IP20
Regulation box	
Mains supply	230V~ 50Hz - 10A max.
Power cable (not supply)	3G0,75 à 1,5mm ² according to local code, Ø ext. 6,5-8mm
Pump power	230V~ 50Hz - 70 W – 0.8A max.
Boiler power (App. Power)	230V~ 50Hz – permanently wired – 1,5 A max. (resistive), 100 000 cycles
Solenoid valve power	230V~ 50Hz - 0.8A max. – NO
External controls relay (Ext. Ctrl.)	NC contact - volt free – 1,5A (resistive) 250V ~ max – 100 000 cycles
Protection	IP20
Regulation box dimensions	L130xW88xH25 mm
Solenoid valve	
Mains supply	230V~ 50Hz - 13 W – 20VA peak
Solenoid valve power (included)	3G0,75mm ² – 2m long – IP65 DIN plug
Valve type	2 ways – Normally Open (Closes water flow when powered)
Fluid	Water only(NBR seals)
Operating pressure	0,3 – 10bar
Kv (flowrate)	12 l/min – Ø int. 10mm
max. temperature	65°C, 90°C in short peak
Protection	IP65
Ports dimensions	G 1/2" - brass – H 65mm

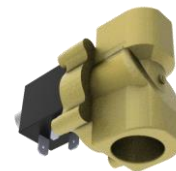
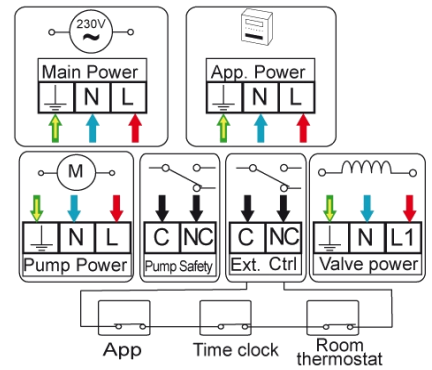

Non-contractual document. We reserve the right to modify the characteristics on our products without prior notice.