

DATA SHEET

# Si-82 Pack 1

## Centrifugal pump

Sauermann® part #: SI82CE04UN23



### Durable pump

The Si-82 pump is designed to be easily installed whatever the layout of the premises. Capable of evacuating up to 500 l/h, the Si-82 pump is suitable for air conditioning units and industrial refrigeration displays. Strong, the Si-82 tolerates charged, high temperature and acidic condensates (pH>2.5) produced by gas condensing boilers.

### Benefits



#### High performance

- Can discharge condensates up to 5 m
- Up to 500 l/h, for shorter running time
- Low sound level – quiet operation



#### Installation in any place

- Pump can be floor mounted, attached on a wall or hanging from a ceiling.



#### Versatile

- Easily removable tank and reversible pump, to allow mounting rather on the left or on the right of the application and choosing the side of the water exit.



#### Easy electrical connection

- Plug-in power cord to facilitate installation and maintenance.



#### Easy hydraulic connection

- Quarter turn easily removable check valve, designed to facilitate Ø int. 10 mm (3/8") hose plug in.
- 4 inlet holes Ø 30 mm (1" 3/16)



#### High resistance

- Oil and acid resistant float
- Mechanical structure resistant to shocks



### Kit content

- One-piece centrifugal pump with tank (2L)
- Integrated barb end check valve ext. Ø 10 mm (3/8")
- Plug-in power (2 m, European plug) & safety switch cord (1.5 m, bare ends)
- Straight connector ext. Ø 10 mm (3/8") – ext. Ø 6 mm (1/4")
- 2 screws + 2 plugs

## Technical specifications

Max. flow rate	500 l/h
Max. discharge head	5 m
Max pressure	5.4 m - flow rate = 0 l/h
<b>Sound level in application at 1 m (3.3 ft)</b> (Measured in Sauermann acoustic lab, pump operating with water)	<b>≤ 45 dBA</b>
Mains supply	230 V~ 50 Hz – 70 W – 0.75 A
Detection levels	On: 53 mm, Off: 42 mm, Safety: 64 mm
Safety switch	NC 4 A resistive – 250 V
Max. condensate temperature	65 °C, 80 °C in short peak
Max. condensate acidity	pH > 2.5 (Gas condensing boilers)
Thermal protection (overheating)	105 °C (auto-reset)
Operating and storage temperature	+2 to +50 °C
Operating conditions	30%: 3s ON – 7s OFF
Protection	IP20
Safety standards	CE, UKCA
RoHS directive	Compliant
WEEE directive	Compliant
Weight (including box)	2.5 kg
Packaging	4 pcs: L 400 x W 300 x H 200 mm
Pallet quantity	64 pieces

## Applications

- Column air conditioning units
- Multi cassettes
- Ducted units
- Gas condensing boilers
- High efficiency gas furnace
- Refrigerating display cabinets
- Evaporators

## Accessories

Name	#Part
 Clear PVC hose int. Ø 10 mm (3/8")	ACC00911: 25 m ACC00915: Braided, 25 m
 Check valve For replacement ext. Ø 10 mm (3/8")	ACC00925
 Inlet rubber adapter int. Ø 15-20-24-32-40 mm (int. Ø 5/8" - 3/4" - 1" - 1 1/4" - 1 1/2")	ACC00939

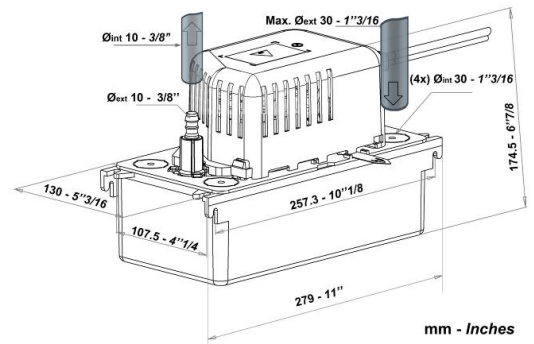

## Actual flow rates (l/h)

Vertical discharge head	Total tube length (Ø int. 10 mm, 3/8")			
	5 m	10 m	20 m	30 m
1 m	380	300	240	190
2 m	310	260	200	150
3 m	240	200	145	110
4 m	150	130	80	60
5 m	30	20	0	0

