

DATA SHEET

Si-82 Pack 1

Centrifugal pump

Sauermann® part #: SI82CE04UN23



Durable pump

The Si-82 pump is designed to be easily installed whatever the layout of the premises. Capable of evacuating up to 500 l/h, the Si-82 pump is suitable for air conditioning units and industrial refrigeration displays. Strong, the Si-82 tolerates charged, high temperature and acidic condensates (pH>2.5) produced by gas condensing boilers.

Benefits



High performance

- Can discharge condensates up to 5 m
- Up to 500 l/h, for shorter running time
- Low sound level – quiet operation



Installation in any place

- Pump can be floor mounted, attached on a wall or hanging from a ceiling.



Versatile

- Easily removable tank and reversible pump, to allow mounting rather on the left or on the right of the application and choosing the side of the water exit.



Easy electrical connection

- Plug-in power cord to facilitate installation and maintenance.



Easy hydraulic connection

- Quarter turn easily removable check valve, designed to facilitate Ø int. 10 mm (3/8") hose plug in.
- 4 inlet holes Ø 30 mm (1" 3/16)



High resistance

- Oil and acid resistant float
- Mechanical structure resistant to shocks



Kit content

- One-piece centrifugal pump with tank (2L)
- Integrated barb end check valve ext. Ø 10 mm (3/8")
- Plug-in power (2 m, European plug) & safety switch cord (1.5 m, bare ends)
- Straight connector ext. Ø 10 mm (3/8") – ext. Ø 6 mm (1/4")
- 2 screws + 2 plugs

Technical specifications

Max. flow rate	500 l/h
Max. discharge head	5 m
Max pressure	5.4 m - flow rate = 0 l/h
Sound level in application at 1 m (3.3 ft) (Measured in Sauermann acoustic lab, pump operating with water)	≤ 45 dBA
Mains supply	230 V~ 50 Hz – 70 W – 0.75 A
Detection levels	On: 53 mm, Off: 42 mm, Safety: 64 mm
Safety switch	NC 4 A resistive – 250 V
Max. condensate temperature	65 °C, 80 °C in short peak
Max. condensate acidity	pH > 2.5 (Gas condensing boilers)
Thermal protection (overheating)	105 °C (auto-reset)
Operating conditions	30%: 3s ON – 7s OFF
Protection	IP20
Safety standards	CE, UKCA
RoHS directive	Compliant
WEEE directive	Compliant
Weight (including box)	2.5 kg
Packaging	4 pcs: L 400 x W 300 x H 200 mm
Pallet quantity	64 pieces

Applications

- Column air conditioning units
- Multi cassettes
- Ducted units
- Gas condensing boilers
- High efficiency gas furnace
- Refrigerating display cabinets
- Evaporators

Accessories

Name	#Part
 Clear PVC hose int. Ø 10 mm (3/8")	ACC00911: 25 m ACC00915: Braided, 25 m
 Check valve For replacement ext. Ø 10 mm (3/8")	ACC00925
 Inlet rubber adapter int. Ø 15-20-24-32-40 mm (int. Ø 5/8" - 3/4" - 1" - 1 1/4" - 1 1/2")	ACC00939

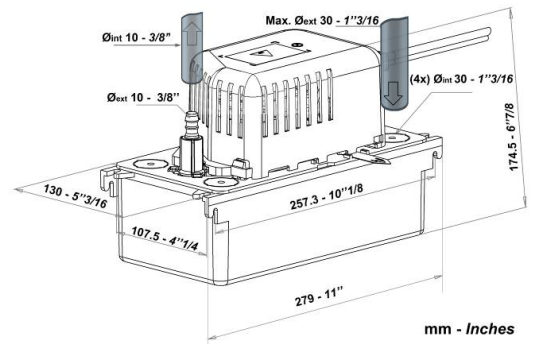

Actual flow rates (l/h)

Vertical discharge head	Total tube length (Ø int. 10 mm, 3/8")			
	5 m	10 m	20 m	30 m
1 m	380	300	240	190
2 m	310	260	200	150
3 m	240	200	145	110
4 m	150	130	80	60
5 m	30	20	0	0

