



DATA SHEET

# Accessories for autonomous Pt100 and thermocouple temperature probes



## Stainless steel thermowells

Operating temperature: From -80°C to +400°C

Protective duct	316L stainless steel, Ø9x1 mm
Mounting	Machine welded
Duct	316L stainless steel
Process connection	316L stainless steel 1/2" G male
Probe connection	316L stainless steel 1/2" G female with 316L stainless steel fixing screw 1/2" G female or thread

GST: Silicone grease in 200 g tube.

Temperature of use	From -60°C to +200°C
Storage	>1 year at room temperature (<50°C)
Solvent	Trichlorethane



Model with thread



Model with fixing screw

Thermowell with thread length:

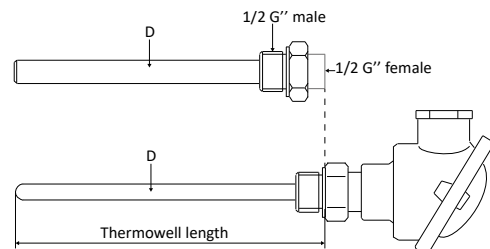

Thermowell with fixing screw length:

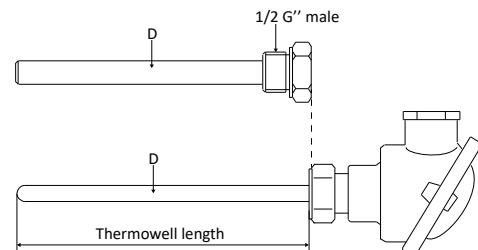

Thermowells references:

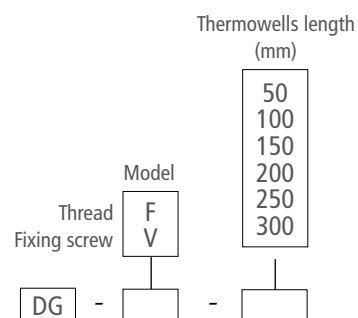

## Mounting brackets

BF-6: 316L stainless steel mounting bracket for duct fixing of Ø6 mm probes

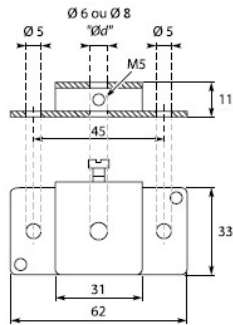
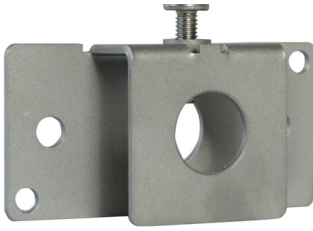

SFM-6 : Wall fixing support for probes Ø 6 mm



RCI-6-12: Stainless steel bicone connector, with stainless steel olive, for probes Ø 6 mm, 1/2 cylindrical gas thread.



RCT-6-12: Stainless steel bicone connector, with PTFE olive, for probes Ø 6 mm, 1/2 cylindrical gas thread.

## Regulated power supply

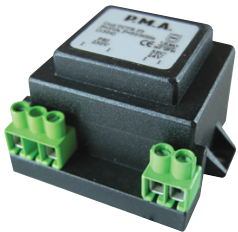

KI-AL-100 A: Class 2 power supply for sensors. Mounting with integrated brackets.

Input voltage: 230 Vac  
Output voltage: 24 Vac  
Intensity: 100 mA



KI-AL-100 C: Class 2 power supply for sensors

Input voltage: 230 Vac  
Output voltage : 24 Vdc  
Intensity: 250 mA

## Transmitters

Head-mounting transmitter



Environmental Conditions

Operating temperature: -40 to +85 °C  
Calibration temperature: 20 to 28 °C  
Relative humidity: <95%HR  
Protection degree (encl/terminal) : IP68/IP00

### Mechanical specifications

Dimensions Ø 44 x 20,2 mm

Weight 50 g

Number of wires 3

Wire size 1 x 1.5 mm<sup>2</sup> stranded wire

Screw terminal torque 0.4 Nm

Vibration IEC 60068-2-6  
from 2 to 25 Hz: ±1.6 mm  
from 20 to 100 Hz: ±4 g

### Common specifications

Supply voltage from 8.0 to 35 Vcc

Internal power dissipation from 25 mW to 0.8 W

Warm-up time	5 minutes
Programming	Loop link
Signal/noise ration	Min. 60 dB
Accuracy	Better than 0.1% of sel. range
Signal dynamics, input	19 bit
Signal dynamics, output	16 bit
Effect of supply voltage change	< 0.005% of EC / Vcc
EMC immunity influence	< ±0.5% of EC

### Input specifications

Max. offset	50% of selected max. value
RTD type	Pt100
Cable resistance per wire	10 Ω (max.)
Sensor current	> 0,2 mA, < 0,4 mA
Effect of sensor cable resistance (3-wire)	< 0,002 Ω / Ω
Sensor error detection	Yes
Linear resistance min....max.	0 Ω...10000 Ω

### Output specifications

Signal range	4...20 mA
Min. signal range	16 mA
Load (@ current output)	$\leq (V_{\text{supply}} - 8) / 0.023 [\Omega]$
Load stability	$\leq 0.01\%$ of span / 100 $\Omega$
Sensor error indication	Programmable 3.5...23 mA
NAMUR NE43 Upscale/Downscale	23 mA / 3.5 mA
Updating time	135 ms

of span = of the presently selected range

We recommend to use a stabilized power supply to supply the transmitter.

### Observed authority requirements

EMC	2014/30/EU
EAC	TR-CU 020/2011
<b>Approvals</b>	
ATEX 2014/34/UE	KEMA 10ATEX0003 X
IECEX	DEK 13.0036X
INMETRO	DEKRA 16.0014 X
CCOE	P337392/3
DNV-GL Marine	Stand. f. Certific. No. 2.4

### Rail-Din transmitter

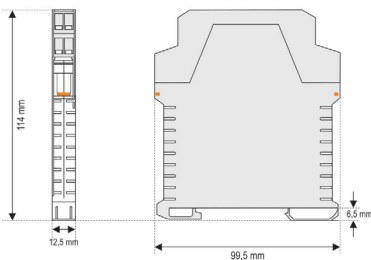
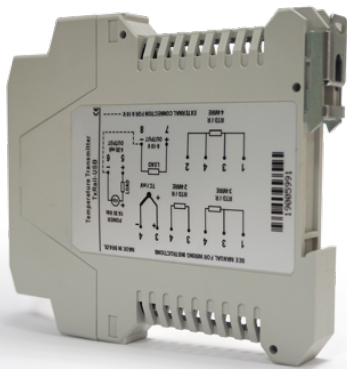

### Measuring range

Pt100: from -200 to +650 °C  
K thermocouple: from -150 to +1370 °C

Temperature dependency	< 0.16 % / 25 °C
Response time	1.6 s
Maximum permissible voltage at the input terminals of the converter	3 V
RTD current	800 $\mu$ A
Resistance effect of RTD cables	0.005 °C / $\Omega$
RTD cable max resistance	25 $\Omega$
Influence of power supply	Typical 006 % / V (percentage of maximum range).
Output (4-20 mA)	Current of 4-20 mA or 20-4 mA, type 2 filis; linear compared to the measured temperature
Output resolution (4-20 mA)	2 $\mu$ A
Output (0-10 Vcc):	Electric voltage of 0-10 Vdc or 10-0 Vdc, linear compared to the measured temperature
Output resolution (0-10 Vcc)	0.0025 V (12 bits)
Power supply	10 to 35 Vdc (4-20 mA output) and 12 to 35 Vdc (0-10 Vc output).
Maximum load	$RL (max.) = (Vdc - 10) / 0.02 [\Omega]$ where : Vdc= power supply voltage in Volts
Operating temperature	from -20 to +50°C
Humidity	from 0 to 90%RH
Connection wire cross section	0.14 to 1.5 mm <sup>2</sup>
Electromagnetical compatibility	EN 61326-1:2006
Housing	ABS UL94-HB
Certification	CE

## Electrical connections

Material	Polyamide
Connection wire cross section	0.14 to 1.5 mm <sup>2</sup>
Screw tightening torque	0.8 Nm

It is important to follow the recommendations below:

Signal wires should be installed in grounded conduits and away from power or contactor wires

The instrument should have its own power supply wires, which should not be shared with electrical motors, coils, contactors, etc.

Installing RC filters is strongly recommended at contactor coils or any other inductors

System failure should always be taken into account when designing a control panel to avoid irreversible damage to equipment or people

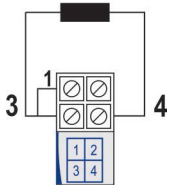

Electrical connection of the converter (Pt100 2-wire)

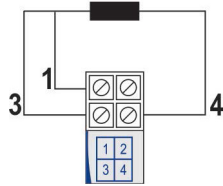

Electrical connection of the converter (Pt100 3-wire)

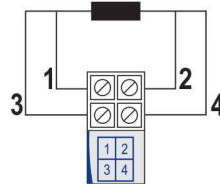

Electrical connection of the converter (Pt100 4-wire)

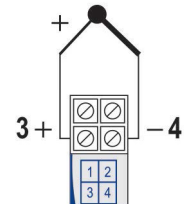

Electrical connection of the converter (Thermocouple)

### Use and configuration

Click here or flash the following code to use and set the Rail-Din converter



## Connectors (only for thermocouple probes)

### Compensated standard connector



Round pin miniature connectors for thermocouple sensors and extension or compensating cable connection. Connector is marked for pin polarity.

Material	Thermoplastic shielded with glass silk
Operating temperature	From -50 to +210°C
Colour code	IEC 584-3

Reference:

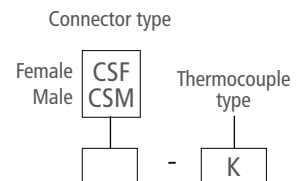

### Compensated miniature connector

Flat pin miniature connectors for thermocouple sensors and extension or compensating cable connection. Connector is marked for pin polarity.



Material	Thermoplastic shielded with glass silk
Operating temperature	From -50 to +210°C
Colour code	IEC 584-3

Reference:

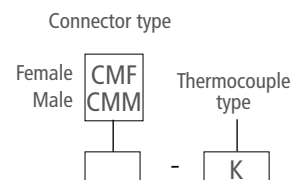

## Wire clamp bracket (only for thermocouple probes)

Stainless steel wire clamp bracket for miniature or standard connectors.

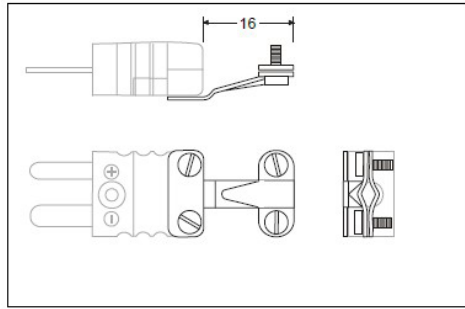

Reference:

