

Si-30 Detect+

PISTON PUMP



Versatile technology

The high performance Si-30 Detect+ is suitable for air-conditioning units **up to 20 kW**.

The piston and detection technology is specifically designed for removing condensates from air conditioning systems.

The Si-30 i Detect+ is fully reliable, in any kind of environment. Its operating sound level will remain silent whatever the volume of condensates.

BENEFITS



● Patented technology

- **Increased performance:** Only one pump, for air conditioning unit up to 20 kW
- **High resistance to pollution** created by general environment. Capable of discharging small particles.
- Detection unit without float to reduce Biofilm effects. (Electronic sensors)
- **Proven Reliability.**
- The **Drain Safe Device** retains prime and prolongs the pump life.

● Silent

- Quiet in operation: **20 dBA independently tested.**
- The size of the air-conditioning unit and volume of condensates to be removed does not affect the operational sound level of the pump.
- **Mounting bracket** specifically designed **to reduce vibration transmission to the wall / panel or pipework.**

● Easy to install

- **Compact design** for the pump and **slim** for the detection unit.
- Pump mounting bracket: allows the pump to be **wall mounted or hung from ceilings and pipework.**
- Detector mounting bracket allows a high stability and a wall mounting.
- **Lockable plug-in power cord** to avoid unintended disconnection.
- **Extended rubber connector** to connect directly to the drip tray.

● Energy saving

- Improved performance and high flow rate **reduce operation time** and energy consumption.

KIT CONTENTS



- Piston pump
- Clear PVC tube Ø int. 6mm – L: 1m, fitted with a « Drain Safe Device » pre-mounted.
- Anti-vibration mounting bracket
- 1.5 m lockable plug-in power cable: 2 power wires, 2 safety switch wires.
- 6 tie wraps, 2.5 x 100mm
- Detection unit (30 cm cable)
- Detection unit installation kit:
 - mounting bracket
 - straight connector
 - 1,5 m extension cable
 - rubber elbow 90° Øint.15 x L 152mm,
 - vent tube Ø int 6 x L 75 mm,
 - 2 self drilling screws + 2 anchors
 - adhesive.

APPLICATIONS

For use with any air-conditioning units, up to 20 kW:

- Wall mounted
- Ceiling suspended
- Ducted
- Fan-coils



TECHNICAL SPECIFICATION

Max. flow rate	20 l/h
Max. suction head	3 m
Max. discharge head	10 m (flow rate =4l/h)
Max pressure	14 m (flow rate =0l/h)
Sound level at 1m according to EN ISO 3744 (Measured at LNE lab, pump operating with water, out of application)	20 dBA
Sound level in application at 1m: (Measured in Sauermann acoustic lab, pump operating with water)	≤ 27 dBA
Mains supply	230V~ 50/60Hz - 14 W
Insulation class	☑ (double insulation)
Detection levels	ON: 18mm, OFF: 11mm, Safety: 25mm
Safety switch	NC 5A resistive – 250V
Thermal protection (overheating)	115°C (auto-reset)
Operating conditions	100% - Continuous duty
Protection	IP20
Safety standards	CE & EAC
RoHS directive	Compliant
WEEE directive	Compliant
Packaging	0.48kg – L135 x W135 x H90 mm
Masterpack	20 pieces

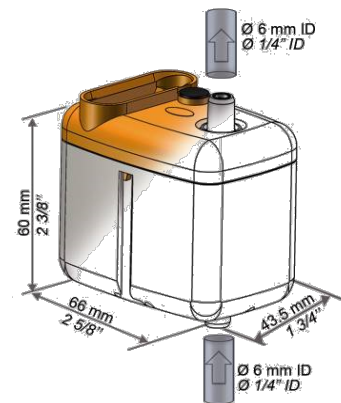
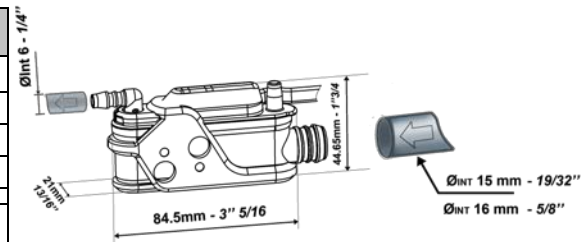

ACTUAL FLOW RATES (l/h)

Suction head (A)	Discharge head (B)	Total hose length using Ø Int 6 mm, 1/4" – (C)			
		5 m	10 m	20 m	30 m
0 m	0 m	20	19	18	17
	2 m	16	15	14	13,5
	4 m	11,5	11	10,5	10
	6 m		8,5	7,5	6,5
	8 m		6	5	4
	10 m		4		
1 m	0 m	14	13	12	11
	2 m	11	10	9	8
	4 m	7,5	7	6	5
	6 m		4,5	4	
2 m	0 m	11	10	9	8
	2 m	9	8	7	6
	4 m		5,5	5	4,5
3 m	0 m	10,5	9	8	7
	2 m	8	7	6	5
	4 m		5	4	

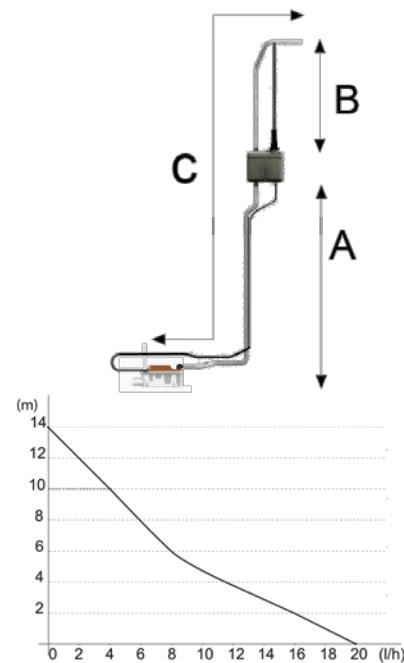

RECOMMENDED ACCESSORIES

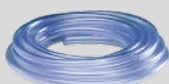

Clear PVC hose Ø int. 6mm (1/4")
ACC00909: 5 m
ACC00910: 50 m



6 Self-sealing fittings for hose
Ø int. 6 mm (1/4")
ACC00919

Non-contractual document. We reserve the right to modify the characteristics on our products without prior notice.