

# ASSEMBLING INSTRUCTION / NOTICE D'INSTALLATION / ISTRUZIONI DI MONTAGGIO

HEAVY DUTY ADJUSTABLE WALL BRACKET WITH CROSSBAR / SUPPORTS "HEAVY-DUTY" AVEC TRAVERSE / STAFFE INDUSTRIALI CON BARRA

STEP  
1



STEP  
2

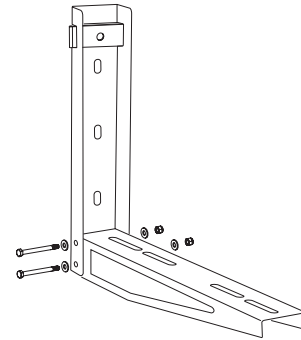

STEP  
3

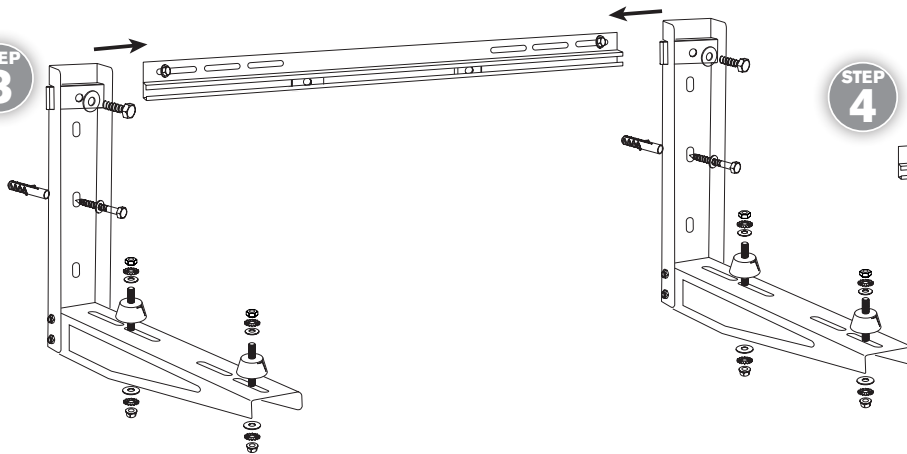

STEP  
4

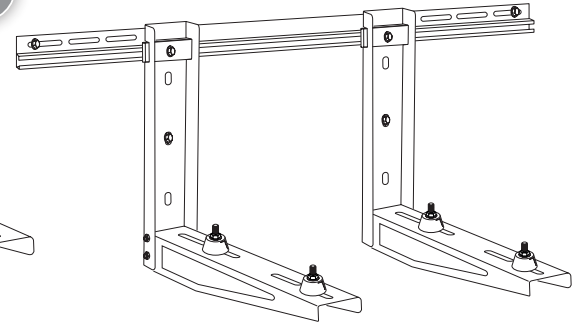

X = 520 mm = 300 KG CERTIFIED / 900 KG TESTED

X = 560 mm = 300 KG CERTIFIED / 900 KG TESTED

## PARTS LIST / LISTE DES COMPOSANTS / CONTENUTO

(Step 1+3)  x4	M8x90 (Step 2)  x4	M8x20 (Step 3)  x2	(Step 3)  x4	 x 1
M10x21 (Step 1+3)  x4	M8 (Step 2)  x4	M8x24 (Step 3)  x6	(Step 3)  x4	
(Step 1)  x2	M8x16 (Step 2+3)  12		M8 (Step 3)  x8	

## WALL BRACKETS FOR AIR CONDITIONING UNITS / SUPPORTS MURAUX POUR CLIMATISEURS / STAFFE DI SUPPORTO PER CLIMATIZZATORI

## EN

- Verify that the wall is suitable for the application. Align the crossbar using the spirit level provided, drill and fix to the wall using fixings provided, suitable for installation in solid masonry (i.e. concrete, brick and tuff). Avoid perforated masonry (i.e. perforated brick, hollow block, semi-solid, plaster boards) which do not guarantee the load capacity.
- Insert provided sliding fasteners into the crossbar (STEP1) and join vertical and horizontal arms, using washers, screws and auto-bloc nuts provided. (STEP 2).
- Scroll the two vertical arms along the crossbar until the necessary distance and fix the brackets to the sliding fasteners by the use of 2 screws and 2 washers provided (STEP 3).
- Use antivibration dampers provided and all remaining fixings to fix the condensing unit to the horizontal arms.
- It is recommended that the installation is periodically inspected.
- Installation to be conducted by qualified personnel only.
- Respect the indicated load capacity, guaranteed only in case of correct installation.

## FR

- Vérifier que le mur est approprié pour l'installation. Fixer la traverse au mur avec les vis et chevilles fournies qui permettent une fixation sur des murs pleins (béton, briques, plâtre). Éviter les murs creux (briques creuses, plaques de plâtre) qui ne garantissent pas les portées.
- Insérer dans la traverse les plaques fournies (STEP1) et assembler le bras horizontal au bras vertical en encastrant et fixant les rondelles, les vis et les écrous autobloquants fournis (STEP 2).
- Faire coulisser les deux bras verticales sur la traverse jusqu'à la réalisation de l'entraxe prévu et fixer le support aux plaques avec les 2 vis et 2 rondelles fournies (STEP 3).
- Utiliser les plots antivibratoire et la visserie restante pour fixer l'unité extérieure aux bras horizontaux. (STEP 3).
- Il est recommandé de vérifier périodiquement l'installation et la fixation au mur.
- Le montage doit être fait par un installateur qualifié et spécialisé.
- Les personnes non autorisées ne doivent pas se trouver sur le lieu de l'installation.
- Respecter les portées indiquées. La garantie n'est applicable que pour les installations respectant les instructions de montage.

## IT

- Verificare che la parete sia adatta all'installazione. Fissare la barra portante al muro con le viti ed i tasselli in dotazione, adatti al fissaggio su muratura piena (calcestruzzo, mattoni pieni, tufo). Evitare muratura forata (mattoni e blocchi forati e semipieni, pannelli in cartongesso e simili) perché le portate non sono garantite (STEP1).
- Inserire all'interno della barra le piastrine fornite (STEP1), ed unire il braccio orizzontale a quello verticale, inserendo e fissando le rondelle, le viti ed i dadi autobloccanti forniti in dotazione (STEP 2).
- Far scorrere i due bracci verticali lungo la barra fino al raggiungimento dell'interasse necessario e fissare la staffa alle piastrine con le 2 viti e 2 rondelle fornite in dotazione (STEP 3).
- Utilizzare gli antivibranti e la restante viteria per fissare l'unità esterna ai bracci orizzontali (STEP3).
- Si consiglia una periodica verifica dell'installazione e del fissaggio a muro.
- Il montaggio va eseguito da personale qualificato e specializzato.
- L'area di montaggio non deve essere frequentata da personale non autorizzato.
- Rispettare le portate indicate, garantite solo in caso di corretta installazione.